

# Over Mantels

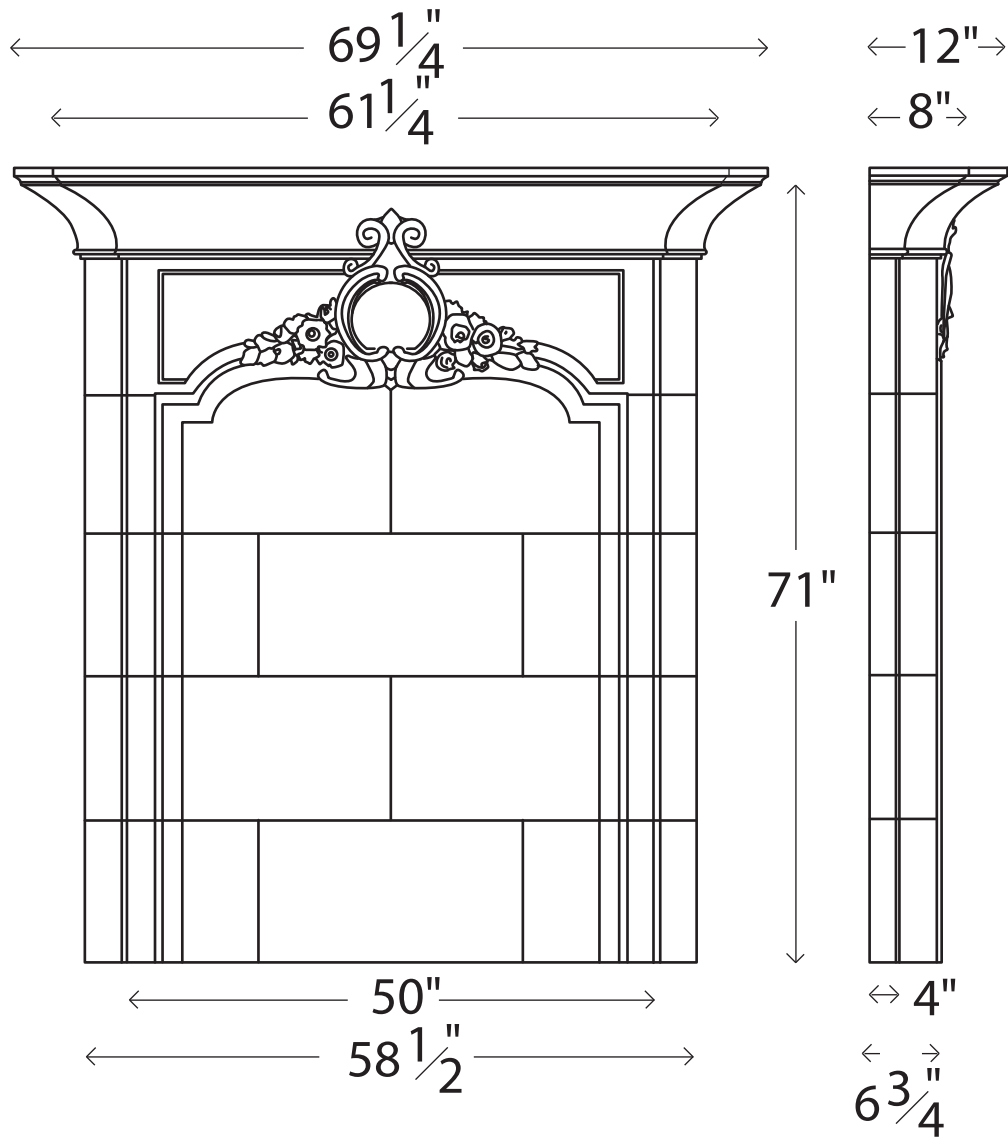

TYPE "K"