

Lausanne

*Available in smaller width

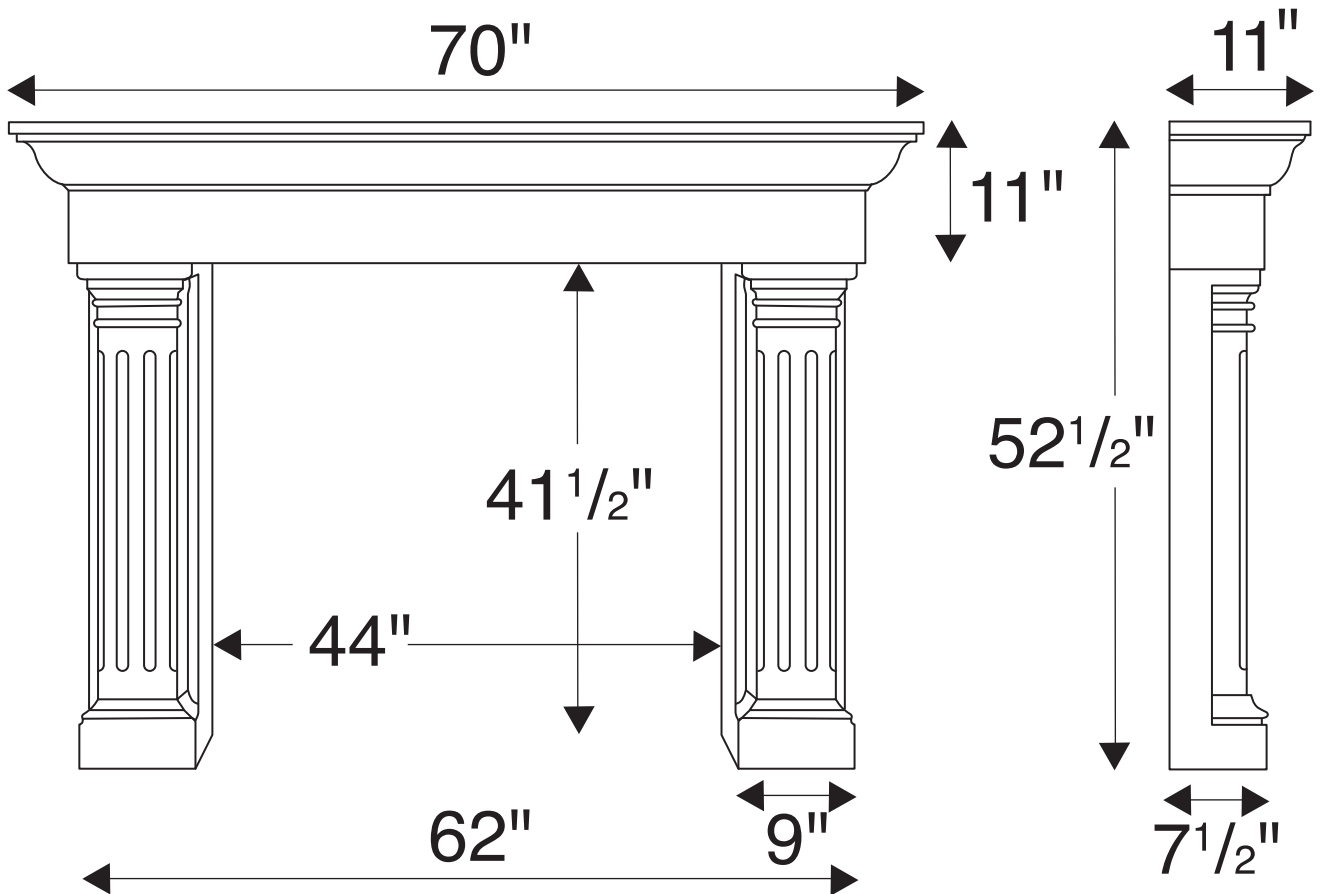

Cast-Stone Fireplace Mantles & Accessories

Multi-Cast Design Inc. - 2800 14th Ave., Unit 5 - Markham, Ontario, Canada - L3R 0E4
Tel 905.477.7330 / 1.888.23.MULTI - Fax 905.477.4330 - www.multicastdesign.com